

Date:	Project Name:
Type:	Part Number:



ZENITH SERIES

LED LINEAR HIGHBAY

DESCRIPTION

Reno Lighting's Zenith Series is the newest addition to our line of LED Highbay fixtures. With its modern and sleek design, it features a slim and light weight profile that will improve the aesthetics of any industrial, commercial or high ceiling retail facility.

FEATURES

- DLC Premium
- 0-10V dimming control compatible
- Shipped with V-Hooks, Chain & 10 FT. Cord
- Operating temperature: -40°F to +122°F (-40°C to +50°C)
- Dual Voltage 120-347V
- Damp location
- Semi-Frosted PMMA lens
- Rated Lifetime L70(hrs): >100,000
- Multi CCT & Wattage
- 10 year warranty

APPLICATIONS

-  Commercial Building
-  Industrial/Warehouse
-  Retail Facility



Date:	Project Name:
Type:	Part Number:

SPECIFICATION

ORDER#	MODEL#	WATTS	VOLTAGE (V)	LUMENS	HOURS RATING	CCT (K)
R34111	RENO-LHB2-DV-MW-MCCT-R1	100/125/140W	120-347V	14,320/17,900/ 20,048 lm	100,000	35/40/50K
R34112	RENO-LHB2-DV-MW-MCCT-R2	145/160/175W	120-347V	20,779/23,248/ 25,428 lm	100,000	35/40/50K
R34113	RENO-LHB2-DV-MW-MCCT-R3	180/210/230W	120-347V	26,334/30,723/ 33,649 lm	100,000	35/40/50K
R34114	RENO-LHB2-DV-MW-MCCT-R4	250/300/340W	120-347V	35,975/43,170/ 48,926 lm	100,000	35/40/50K
R34115	RENO-LHB2-DV-MW-MCCT-R5	340/380/420/450W	120-347V	51,000/57,000/ 63,000/ 67,500 lm	100,000	35/40/50K

ACCESSORIES

ORDER#	MODEL#	DESCRIPTION
R39301	RENO-LHB-HPM	Center Box for Pendant Mounting - R1
R39305	RENO-LHB-CK-R1	Connection Kit for ganging Highbays R1
R39306	RENO-LHB-CK-R2/R3	Connection Kit for ganging Highbays R2/R3
R39303	RENO-LHB-WG-R1	Wire Guards for Linear Highbays R1
R39304	RENO-LHB-WG-R2	Wire Guards for Linear Highbays R2



RENO-LHB-HPM



RENO-LHB-CK-R1



RENO-LHB-CK-R2/R3

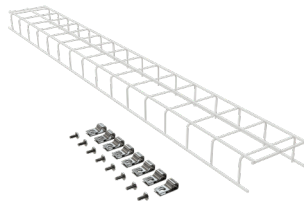

RENO-LHB-WG-R1

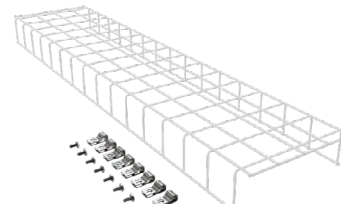

RENO-LHB-WG-R2



Date:	Project Name:
Type:	Part Number:

SENSOR OPTIONS

ORDER#	MODEL#	DESCRIPTION
R71002	RENO-SENSOR-MW-H	Bi-Level Dim Sensor for Linear Highbay



RENO-SENSOR-MW-H

REMOTE OPTIONS

ORDER#	MODEL#	DESCRIPTION
R73002	RENO-REMOTE-H	Controller for Bi-Level Sensor (with screen)
R73005	RENO-REMOTE-H-ECO	ECO Remote control (without screen)



RENO-REMOTE-H



RENO-REMOTE-H-ECO

EMERGENCY BATTERY

ORDER#	MODEL#	DESCRIPTION
R83002	RENO-EM-H25	Emergency LED Driver (100-347Vac, 50/60Hz, 25W)
R83003	RENO-EM-H40	Emergency LED Driver (100-347Vac, 50/60Hz, 40W)



RENO-EM-H25



RENO-EM-H40 (with test switch)

Date:	Project Name:
Type:	Part Number:

DIMENSIONS

R1 11 lbs

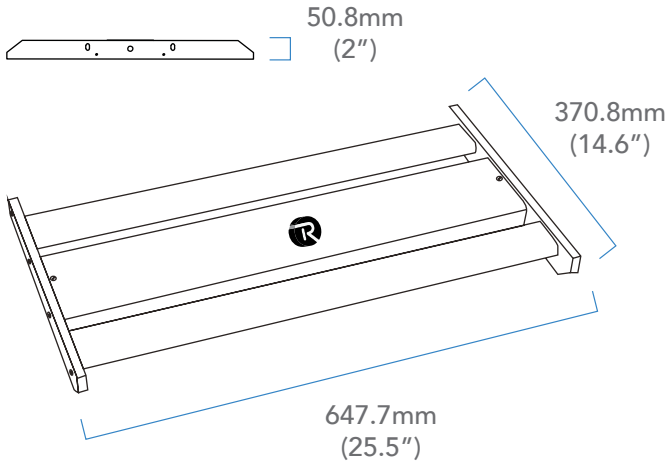

R2 15 lbs

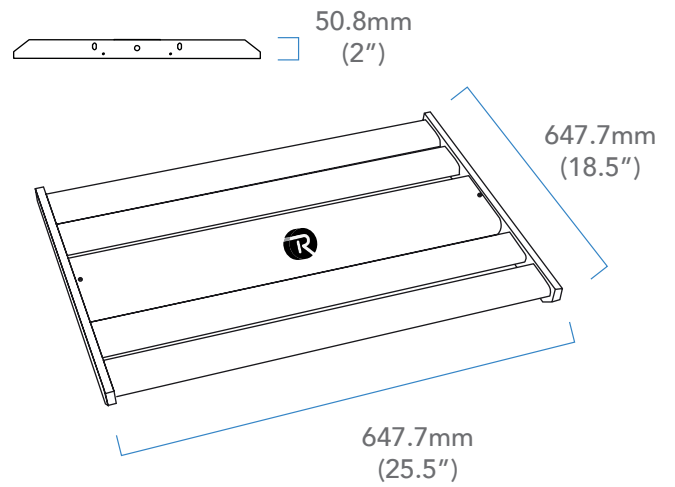

R3 19 lbs

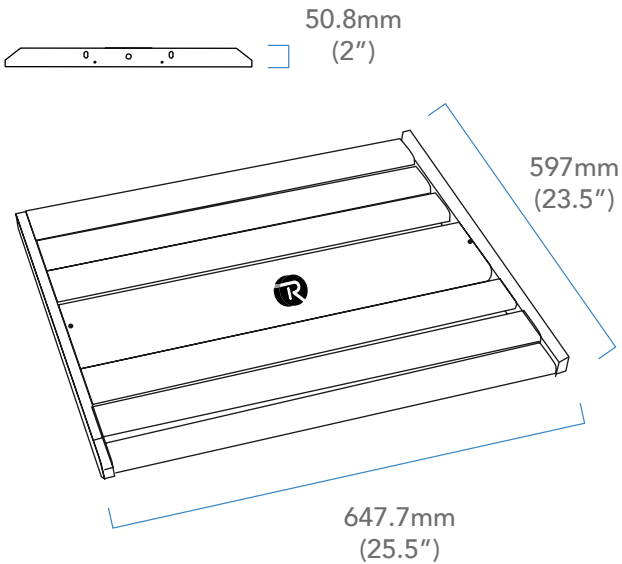

R4 24 lbs

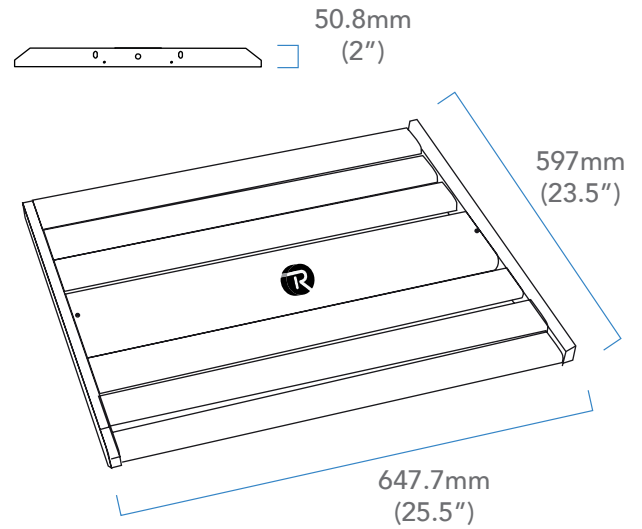

R5 48 lbs

